

Installation Note

**Extended Power Range and Bias Tees Upgrade Kit
To Upgrade Option 200 to Option 219**

Upgrade Kit Order Number: N5242AU- 921



Agilent Kit Number: N5242-60101
Agilent Document Number: N5242-90002
Printed in USA August 2008
Supersedes: September 2007
© Agilent Technologies, Inc. 2007, 2008



WARRANTY STATEMENT

THE MATERIAL CONTAINED IN THIS DOCUMENT IS PROVIDED “AS IS,” AND IS SUBJECT TO BEING CHANGED, WITHOUT NOTICE, IN FUTURE EDITIONS. FURTHER, TO THE MAXIMUM EXTENT PERMITTED BY APPLICABLE LAW, AGILENT DISCLAIMS ALL WARRANTIES, EITHER EXPRESS OR IMPLIED WITH REGARD TO THIS MANUAL AND ANY INFORMATION CONTAINED HEREIN, INCLUDING BUT NOT LIMITED TO THE IMPLIED WARRANTIES OF MERCHANTABILITY AND FITNESS FOR A PARTICULAR PURPOSE. AGILENT SHALL NOT BE LIABLE FOR ERRORS OR FOR INCIDENTAL OR CONSEQUENTIAL DAMAGES IN CONNECTION WITH THE FURNISHING, USE, OR PERFORMANCE OF THIS DOCUMENT OR ANY INFORMATION CONTAINED HEREIN. SHOULD AGILENT AND THE USER HAVE A SEPARATE WRITTEN AGREEMENT WITH WARRANTY TERMS COVERING THE MATERIAL IN THIS DOCUMENT THAT CONFLICT WITH THESE TERMS, THE WARRANTY TERMS IN THE SEPARATE AGREEMENT WILL CONTROL.

DFARS/Restricted Rights Notice

If software is for use in the performance of a U.S. Government prime contract or subcontract, Software is delivered and licensed as “Commercial computer software” as defined in DFAR 252.227-7014 (June 1995), or as a “commercial item” as defined in FAR 2.101(a) or as “Restricted computer software” as defined in FAR 52.227-19 (June 1987) or any equivalent agency regulation or contract clause. Use, duplication or disclosure of Software is subject to Agilent Technologies’ standard commercial license terms, and non-DOD Departments and Agencies of the U.S. Government will receive no greater than Restricted Rights as defined in FAR 52.227-19(c)(1-2) (June 1987). U.S. Government users will receive no greater than Limited Rights as defined in FAR 52.227-14 (June 1987) or DFAR 252.227-7015 (b)(2) (November 1995), as applicable in any technical data.

Safety Notes

The following safety notes are used throughout this document. Familiarize yourself with each of these notes and its meaning before performing any of the procedures in this document.

WARNING	Warning denotes a hazard. It calls attention to a procedure which, if not correctly performed or adhered to, could result in injury or loss of life. Do not proceed beyond a warning note until the indicated conditions are fully understood and met.
----------------	---

CAUTION	Caution denotes a hazard. It calls attention to a procedure that, if not correctly performed or adhered to, could result in damage to or destruction of the instrument. Do not proceed beyond a caution sign until the indicated conditions are fully understood and met.
----------------	---

Getting Assistance from Agilent

By internet, phone, or fax, get assistance with all your test and measurement needs.

Contacting Agilent

Assistance with test and measurements needs and information on finding a local Agilent office are available on the Web at:

<http://www.agilent.com/find/assist>

If you do not have access to the Internet, please contact your Agilent field engineer.

NOTE In any correspondence or telephone conversation, refer to the Agilent product by its model number and full serial number. With this information, the Agilent representative can determine whether your product is still within its warranty period.

Description of the Upgrade

This upgrade converts your standard 2-port configurable test set analyzer (N5242A Option 200) to an extended power range analyzer with bias tees. After installation of this upgrade, your analyzer will be an N5242A Option 219.

This option adds a 60-dB source attenuator and a bias tee in each source port channel and a 35-dB receiver attenuator in each receiver channel.

About Installing the Upgrade

Products affected	N5242A Option 200
Installation to be performed by	Agilent service center or personnel qualified by Agilent
Estimated installation time	1.5 hours
Estimated adjustment time	0.5 hours
Estimated full instrument calibration time	2.0 hours

Items Included in the Upgrade Kit

Check the contents of your kit against the following list. If any part is missing or damaged, contact Agilent Technologies. Refer to [“Getting Assistance from Agilent” on page 3](#).

Table 1 Contents of Upgrade Kit N5242-60101

Ref Desig.	Description	Qty	Part Number
	Installation note	1	N5242-90002
A34, A37	0–60 dB source step attenuator	2	33321-60070
A38, A41	Bias tee (includes wire harness, part number 8121-0836)	2	5087-7239
A42, A45	0-35 dB receiver step attenuator	2	33321-60066
	Attenuator bracket	2	N5242-00007
	Machine screw, M3 x 8, pan head (to attach attenuator to attenuator bracket)	8	0515-0372
	Machine screw, M3 x 14, pan head (to attach bias tee to attenuator bracket)	4	0515-0665
	Machine screw, M3 x 6, pan head (to attach attenuator bracket to analyzer)	6	0515-0430
W25	RF cable, A28 test port 2 bridge to front-panel REF 2 SOURCE OUT	1	N5242-20048
W37	RF cable, A33 reference mixer switch to A23 mixer brick (R1)	1	N5242-20009
W71	RF cable, A25 test port 1 bridge to A34 test port 1 source attenuator	1	N5242-20005
W72	RF cable, A34 test port 1 source attenuator to Port 1 SOURCE OUT	1	N5242-20038
W73	RF cable, Port 1 CPLR THRU to A38 test port 1 bias tee	1	N5242-20039
W119	RF cable, A38 test port 1 bias tee to A29 test port 1 coupler	1	N5242-20115
W83	RF cable, A28 test port 2 bridge to A37 test port 2 source attenuator	1	N5242-20002
W84	RF cable, A37 test port 2 source attenuator to Port 2 SOURCE OUT	1	N5242-20046
W85	RF cable, Port 2 CPLR THRU to A41 test port 2 bias tee	1	N5242-20045
W120	RF cable, A41 test port 2 bias tee to A32 test port 2 coupler	1	N5242-20108
W87	RF cable, Port 1 RCVR A IN to A42 port 1 receiver attenuator	1	N5242-20041
W88	RF cable, A42 port 1 receiver attenuator to A23 mixer brick (A)	1	N5242-20010
W93	RF cable, Port 2 RCVR B IN to A45 port 2 receiver attenuator	1	N5242-20047
W94	RF cable, A45 port 2 receiver attenuator to A23 mixer brick (B)	1	N5242-20016
	Ribbon cable, A19 test set motherboard J205 to A42 port 1 receiver attenuator	2	N5242-60007
	Ribbon cable, A19 test set motherboard J208 to A45 port 2 receiver attenuator		
	Ribbon cable, A19 test set motherboard J201 to A34 test port 1 source attenuator	2	N5242-60008
	Ribbon cable, A19 test set motherboard J204 to A37 test port 2 source attenuator		

Installation Procedure for the Upgrade

The network analyzer must be in proper working condition prior to installing this option. Any necessary repairs must be made before proceeding with this installation.

WARNING **This installation requires the removal of the analyzer’s protective outer covers. The analyzer must be powered down and disconnected from the mains supply before performing this procedure.**

Electrostatic Discharge Protection

Protection against electrostatic discharge (ESD) is essential while removing or connecting cables or assemblies within the network analyzer.

Static electricity can build up on your body and can easily damage sensitive internal circuit elements when discharged. Static discharges too small to be felt can cause permanent damage. To prevent damage to the instrument:

- *always* have a grounded, conductive table mat in front of your test equipment.
- *always* wear a grounded wrist strap, connected to a grounded conductive table mat, having a 1 M Ω resistor in series with it, when handling components and assemblies or when making connections.
- *always* wear a heel strap when working in an area with a conductive floor. If you are uncertain about the conductivity of your floor, wear a heel strap.
- *always* ground yourself before you clean, inspect, or make a connection to a static-sensitive device or test port. You can, for example, grasp the grounded outer shell of the test port or cable connector briefly.

Figure 1 shows a typical ESD protection setup using a grounded mat and wrist strap. Refer to “Tools and Equipment Required for the Installation” on page 6 for part numbers.

Figure 1 ESD Protection Setup

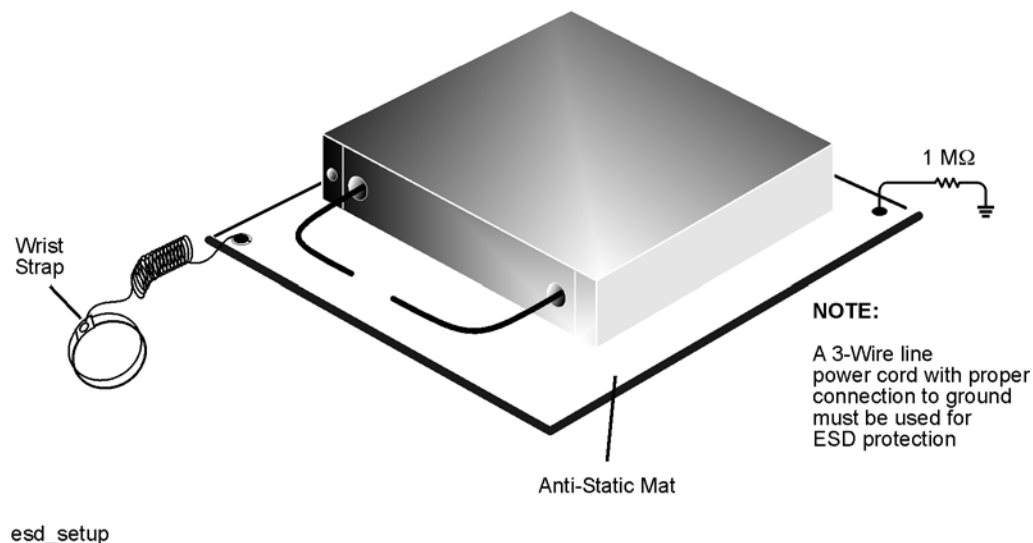

Tools and Equipment Required for the Installation

Description	Qty	Part Number
T-10 TORX driver (set to 9 in-lbs)	1	N/A
T-20 TORX driver (set to 21 in-lbs)	1	N/A
5/16-in torque wrench (set to 10 in-lbs)	1	N/A
5/16-in torque wrench (set to 21 in-lbs)	1	N/A

CAUTION Use a 5/16-in torque wrench set to 10 in-lbs on all cable connections except the front-panel cable connectors. Use a 5/16-in torque wrench set to 21 in-lbs for these connections.

ESD Equipment and Supplies Required for the Installation

Description	Agilent Part Number
ESD grounding wrist strap	9300-1367
5-ft grounding cord for wrist strap	9300-0980
2 x 4 ft conductive table mat and 15-ft grounding wire	9300-0797
ESD heel strap (for use with conductive floors)	9300-1308

Overview of the Installation Procedure

Step 1. [Remove the Outer Cover.](#)

Step 2. [Remove the Front Panel Assembly.](#)

Step 3. [Remove the Existing Cables.](#)

Step 4. [Assemble the Step Attenuators and Bias Tees.](#)

Step 5. [Install the Step Attenuators and Bias Tees into the Analyzer.](#)

Step 6. [Install the New Cables.](#)

Step 7. [Reinstall the Front Panel Assembly and Front Panel Jumpers.](#)

Step 8. [Reinstall the Outer Cover.](#)

Step 9. [Enable Option 219.](#)

Step 10. [Perform Post-Upgrade Adjustments and Calibration.](#)

Step 1. Remove the Outer Cover

CAUTION This procedure is best performed with the analyzer resting on its front handles in the vertical position. *Do not place the analyzer on its front panel without the handles.* This will damage the front panel assemblies.

Refer to [Figure 2](#) for this step of the procedure.

1. Disconnect the power cord (if it has not already been disconnected).
2. Remove the strap handles (item ①) by loosening the screws (item ②), with a T-20 TORX driver, on both ends until the handle is free of the analyzer.
3. Remove the foot locks (item ③) from the four bottom feet (item ④) and then remove the four bottom feet from the outer cover.
4. Remove the four rear panel feet (item ⑤) by removing the center screws (item ⑥) with a T-20 TORX driver,.
5. Slide the outer cover toward the rear of the analyzer and remove it.

Figure 2 Outer Cover Removal

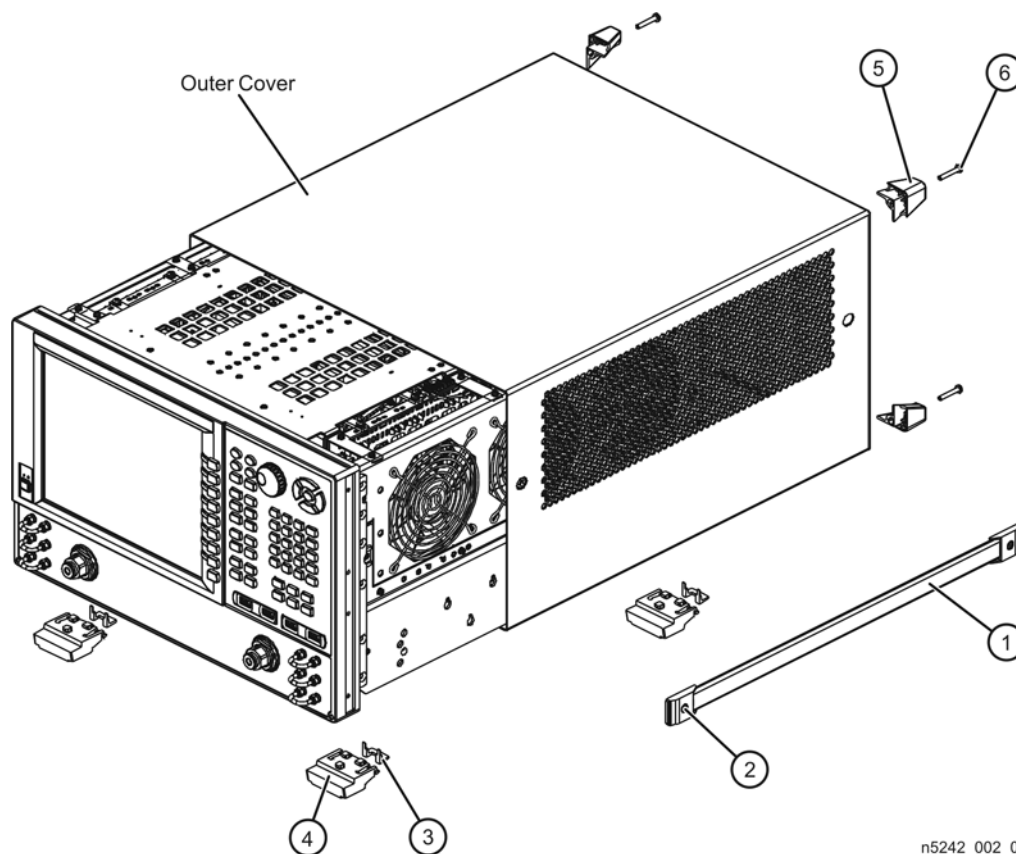

Step 2. Remove the Front Panel Assembly

Refer to [Figure 3](#) for this step of the procedure.

1. With a 5/16-in wrench, remove all front panel jumpers (item ①).
2. With a T-10 TORX driver, remove the screws (item ②) from the sides of the frame.

CAUTION Before removing the front panel from the analyzer, lift and support the front of the analyzer chassis.

3. Slide the front panel over the test port connectors.
4. Disconnect the front panel interface ribbon cable (item ③). The front panel is now free from the analyzer.

Figure 3 Front Panel Assembly Removal

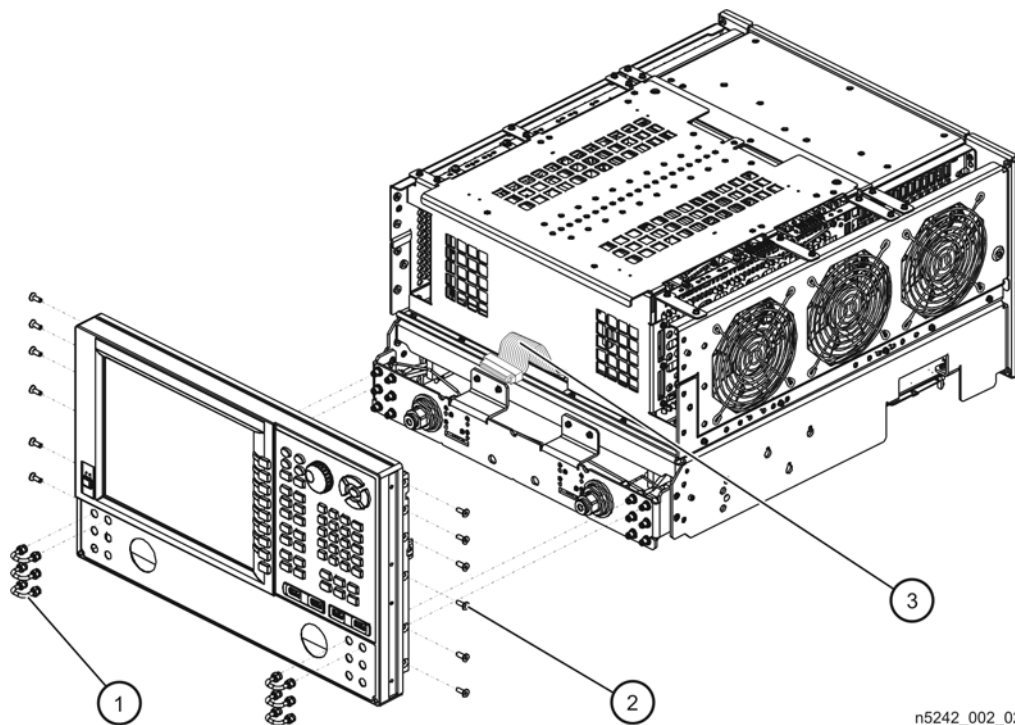

n5242_002_02

Step 3. Remove the Existing Cables

Refer to [Figure 4](#) for this step of the procedure.

1. Place the analyzer bottom-side up on a flat surface.
2. Remove the following cables in the order listed:
 - W31 Front-panel Port 1 RCVR A IN to A23 mixer brick (A)
 - W34 Front-panel Port 2 RCVR B IN to A23 mixer brick (B)
 - W114 Front-panel Port 1 CPLR THRU to A29 test port 1 coupler
 - W116 Front-panel Port 2 CPLR THRU to A32 test port 2 coupler
 - W11 A25 port 1 bridge to front-panel Port 1 SOURCE OUT
 - W23 A28 port 2 bridge to front-panel Port 2 SOURCE OUT
 - W48 A33 reference mixer switch to A23 mixer brick (R1)
 - W27 A28 port 2 bridge to front-panel REF 2 SOURCE OUT

Figure 4 Existing Cable Removal

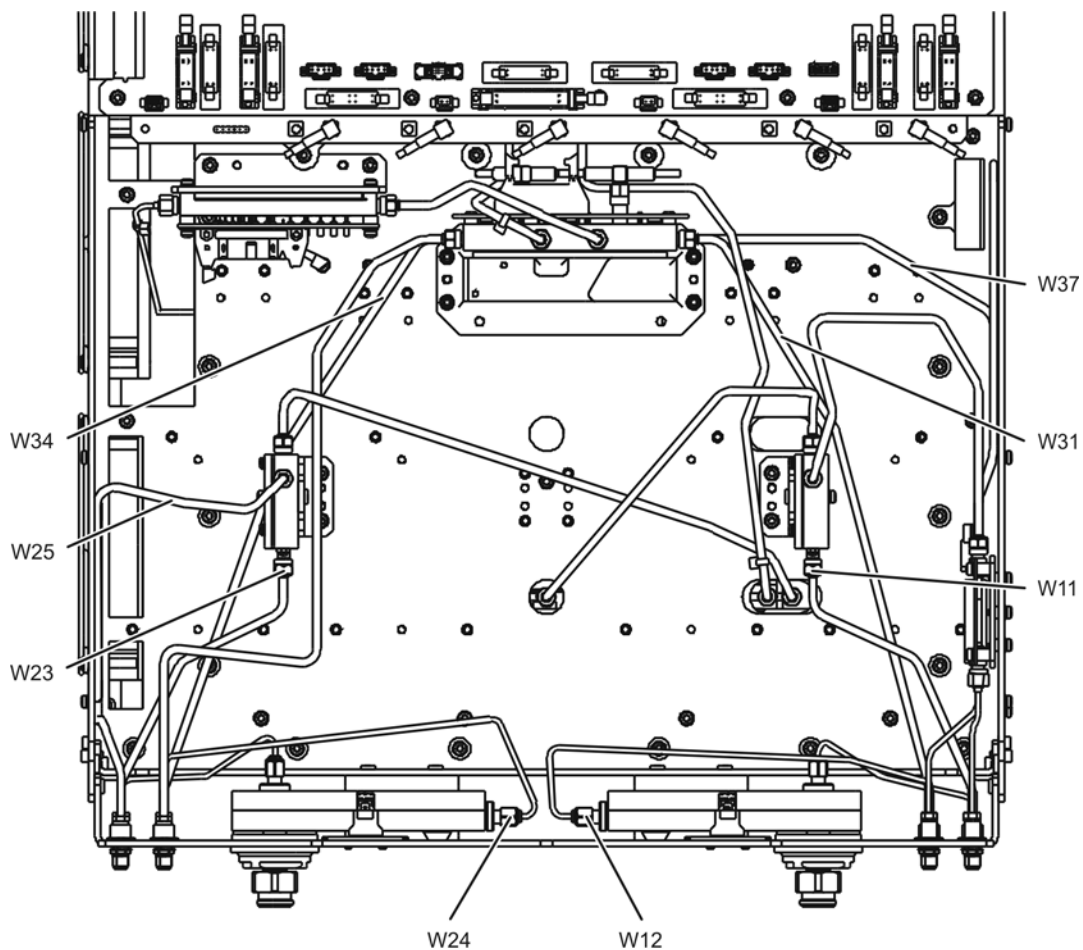

n5242_002_03

Step 4. Assemble the Step Attenuators and Bias Tees

Refer to [Figure 6](#) for this procedure. New parts are listed in [Table 1 on page 4](#).

1. Position the source and receiver attenuators on the attenuator brackets as shown.
2. Secure each attenuator to its attenuator bracket using two screws (item ① - 0515-0372) for each. Make sure that the attenuators are oriented as shown.
3. Position the bias tees on the attenuator brackets as shown.
4. Secure each bias tee to the attenuator brackets using two screws (item ② - 0515-0665) for each. Make sure that the attenuators are oriented as shown.

Figure 5 Step Attenuators and Bias Tees Assembly

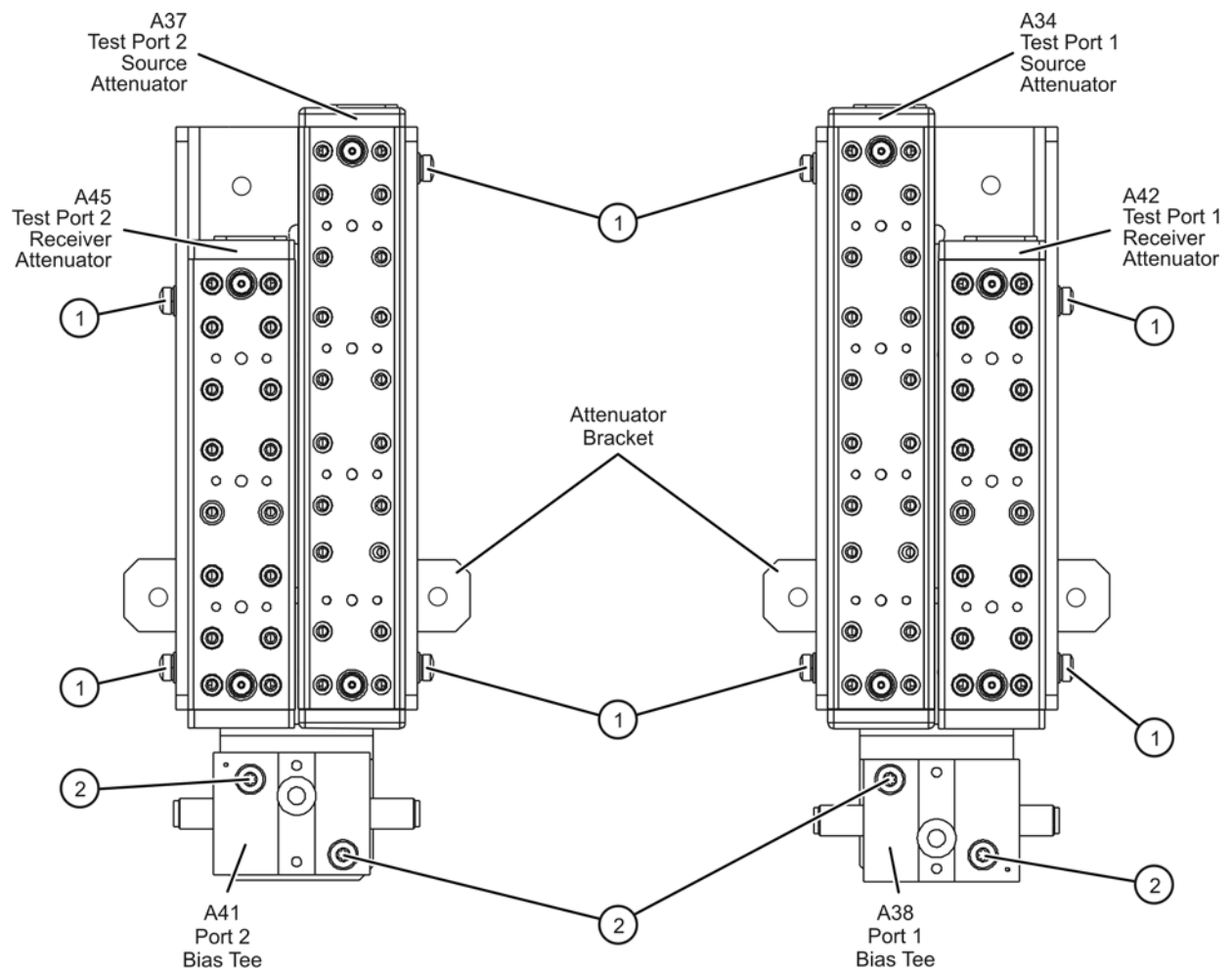

n5242_002_04

Step 5. Install the Step Attenuators and Bias Tees into the Analyzer

Refer to [Figure 6](#) for this procedure. New parts are listed in [Table 1 on page 4](#).

1. Position the attenuator brackets (with the attenuators and bias tees attached) in the analyzer as shown.
2. Secure the attenuator brackets to the analyzer test set deck using three screws (item ① - 0515-0430) each.

Figure 6 Step Attenuators and Bias Tees Installation into the Analyzer

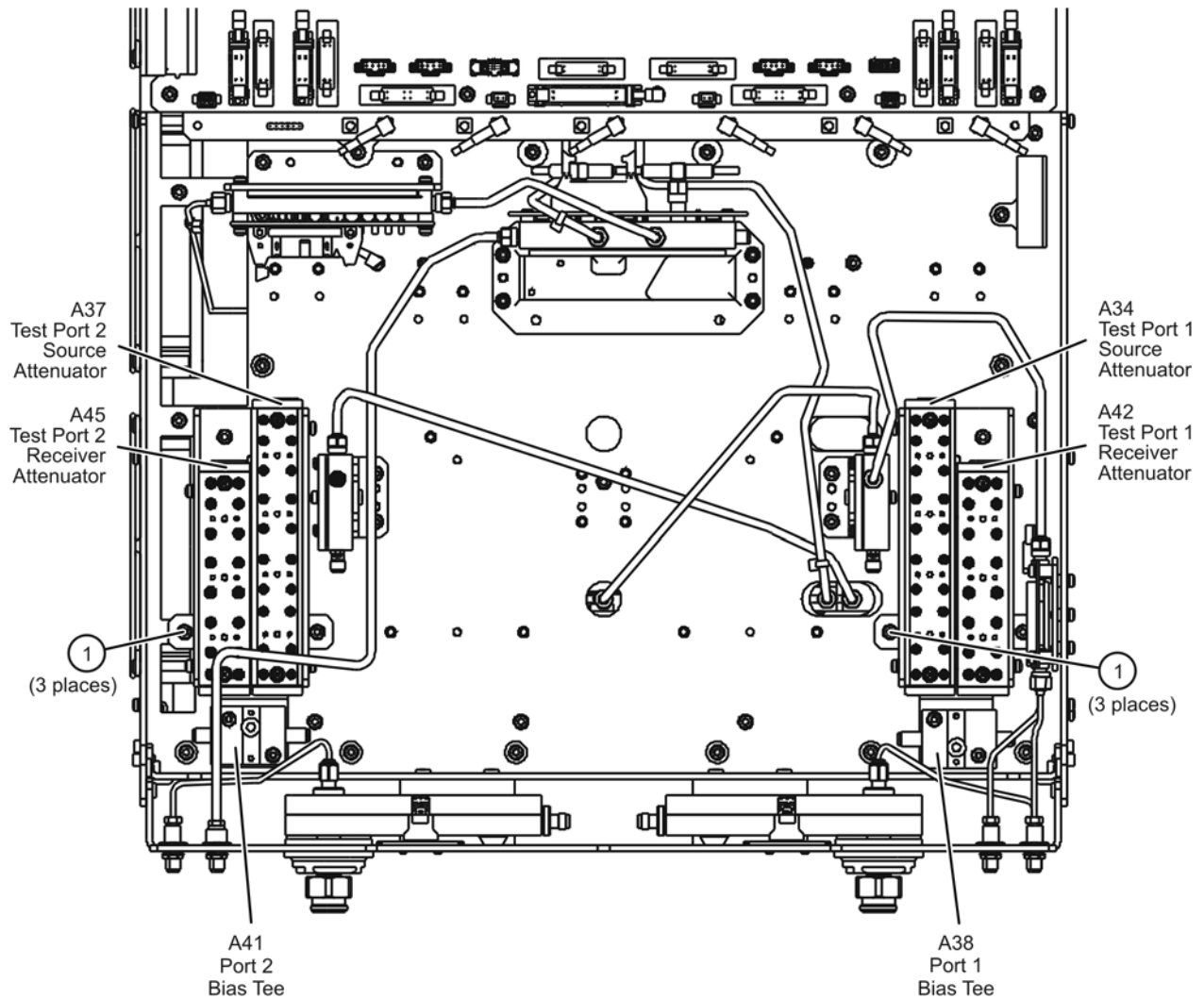

n5242_002_05

Step 6. Install the New Cables

Refer to [Figure 7](#) for the following procedure. New parts are listed in [Table 1 on page 4](#).

1. Install the following cables in the order listed. Use a 5/16-in torque wrench set to 10 in-lbs to tighten all cable connectors.
 - W93 Front-panel Port 2 RCVR B IN to A45 port 2 receiver attenuator
 - W85 Front-panel Port 2 CPLR THRU to A41 test port 2 bias tee
 - W84 A37 test port 2 source attenuator to front-panel Port 2 SOURCE OUT
 - W120 A41 test port 2 bias tee to A32 test port 2 coupler
 - W87 Front-panel Port 1 RCVR A IN A42 port 1 receiver attenuator
 - W73 Front-panel Port 1 CPLR THRU to A38 test port 1 bias tee
 - W72 A34 test port 1 source attenuator to front-panel Port 1 SOURCE OUT
 - W119 A38 test port 1 bias tee to A29 test port 1 coupler
 - W83 A28 test port 2 bridge to A37 test port 2 source attenuator
 - W25 A28 port 2 bridge to front-panel REF 2 SOURCE OUT
 - W71 A25 test port 1 bridge to A34 test port 1 source attenuator
 - W37 A33 reference mixer switch to A23 mixer brick (R1)
 - W88 A42 port 1 receiver attenuator to A23 mixer brick (A)
 - W94 A45 port 2 receiver attenuator to A23 mixer brick (B)
2. Using a 5/16-in torque wrench set to 21 in-lbs, tighten the hex nuts (item ①) on all front panel cable connectors.
3. Connect a ribbon cable to each of the step attenuator connectors:
 - a. Item ② connects between the A42 port 1 receiver attenuator and A19 test set motherboard connector J205.
 - b. Item ③ connects between the A34 test port 1 source attenuator and A19 test set motherboard connector J201.
 - c. Item ④ connects between the A45 port 2 receiver attenuator and A19 test set motherboard connector J208.
 - d. Item ⑤ connects between the A37 test port 2 source attenuator and A19 test set motherboard connector J204.
4. Connect the bias tee cables:
 - a. Item ⑥ connects between the A38 test port 1 bias tee and A19 test set motherboard connector J541.
 - b. Item ⑦ connects between the A41 test port 2 bias tee and A19 test set motherboard connector J542.

Figure 7 New Cable Installation

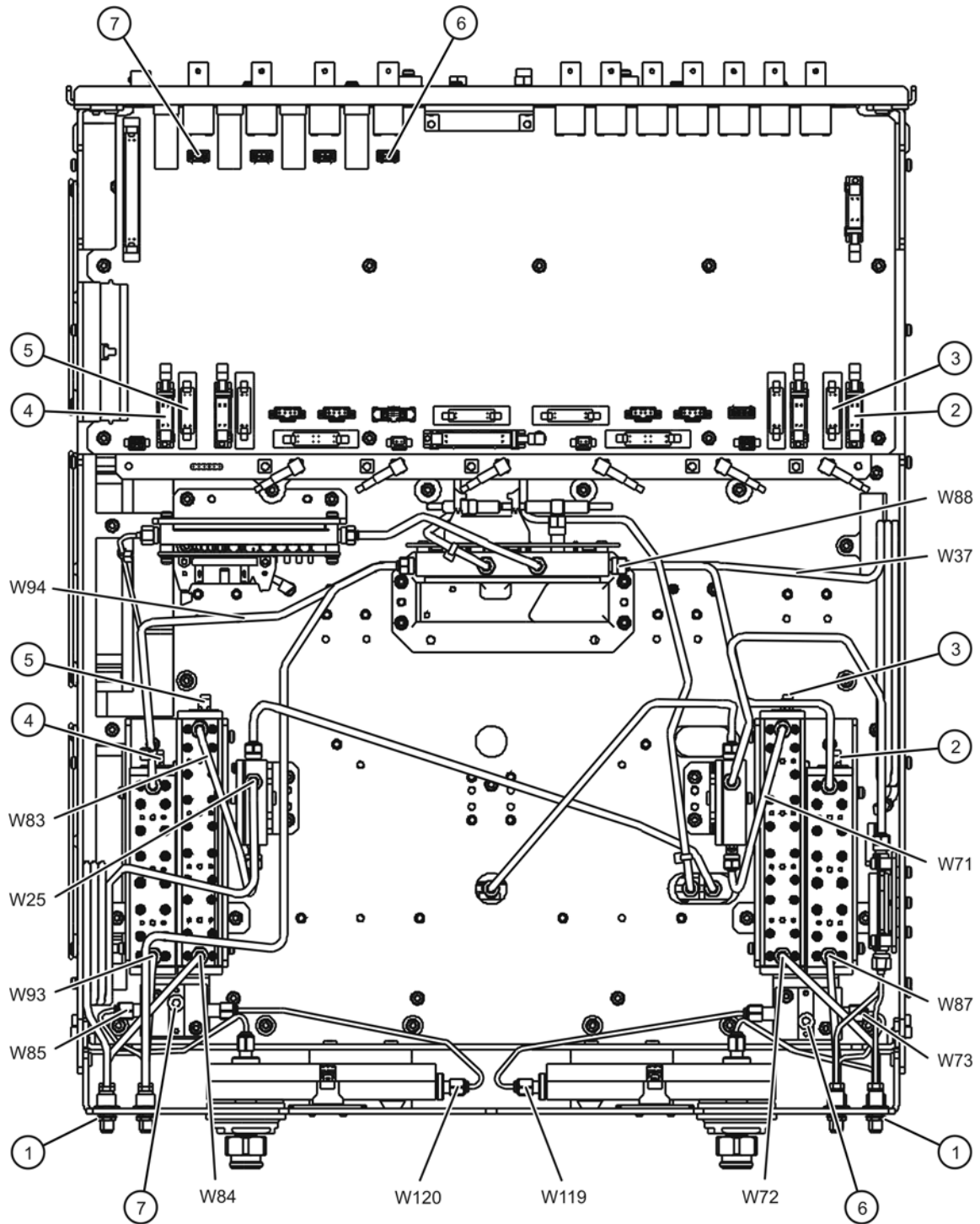

n5242_002_06

Step 7. Reinstall the Front Panel Assembly and Front Panel Jumpers

CAUTION Before installing the front panel assembly onto the analyzer, lift and support the front of the analyzer chassis.

Refer to [Figure 8](#) for this procedure. New parts are listed in [Table 1 on page 4](#).

1. Make sure all of the hex nuts on the front-panel cable connectors have been tightened using a 5/16-in torque wrench set to 21-in lbs.
2. Reconnect the ribbon cable (item ③) to the A1 front panel interface board.
3. Slide the front panel over the front-panel connectors.
4. With a T-10 TORX driver, reinstall the 12 screws (item ②) in the sides of the frame.
5. Reinstall the semirigid jumpers (item ①) on the front panel, and tighten each of the connectors to 10-in lbs.

Figure 8 Front Panel Assembly Reinstallation

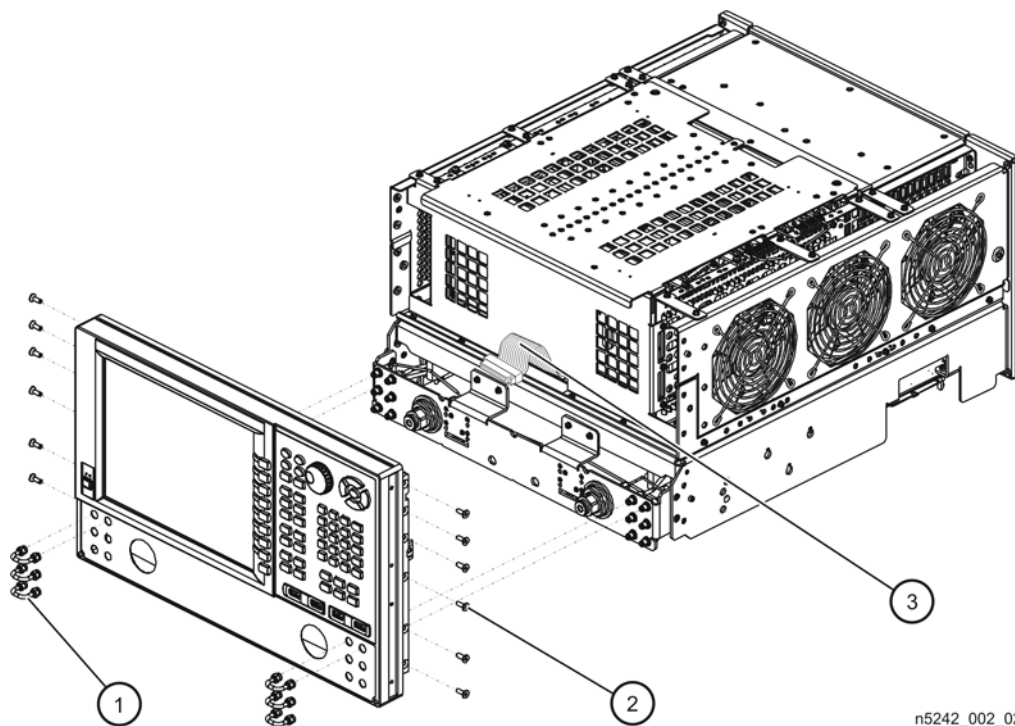

n5242_002_02

Step 8. Reinstall the Outer Cover

CAUTION This procedure is best performed with the analyzer resting on its front handles in the vertical position. *Do not place the analyzer on its front panel without the handles.* This will damage the front panel assemblies.

Refer to [Figure 9](#) for this procedure.

1. Slide the outer cover over the analyzer frame.
2. Install the four rear panel feet (item ⑤) by installing the center screws (item ⑥) with a T-20 TORX driver.
3. Install the four bottom feet (item ④) onto the bottom of the outer cover then install the foot locks (item ③).
4. Install the strap handles (item ①) by tightening the screws (item ②) on both ends of the strap handle with a T-20 TORX driver.

Figure 9 Outer Cover Reinstallation

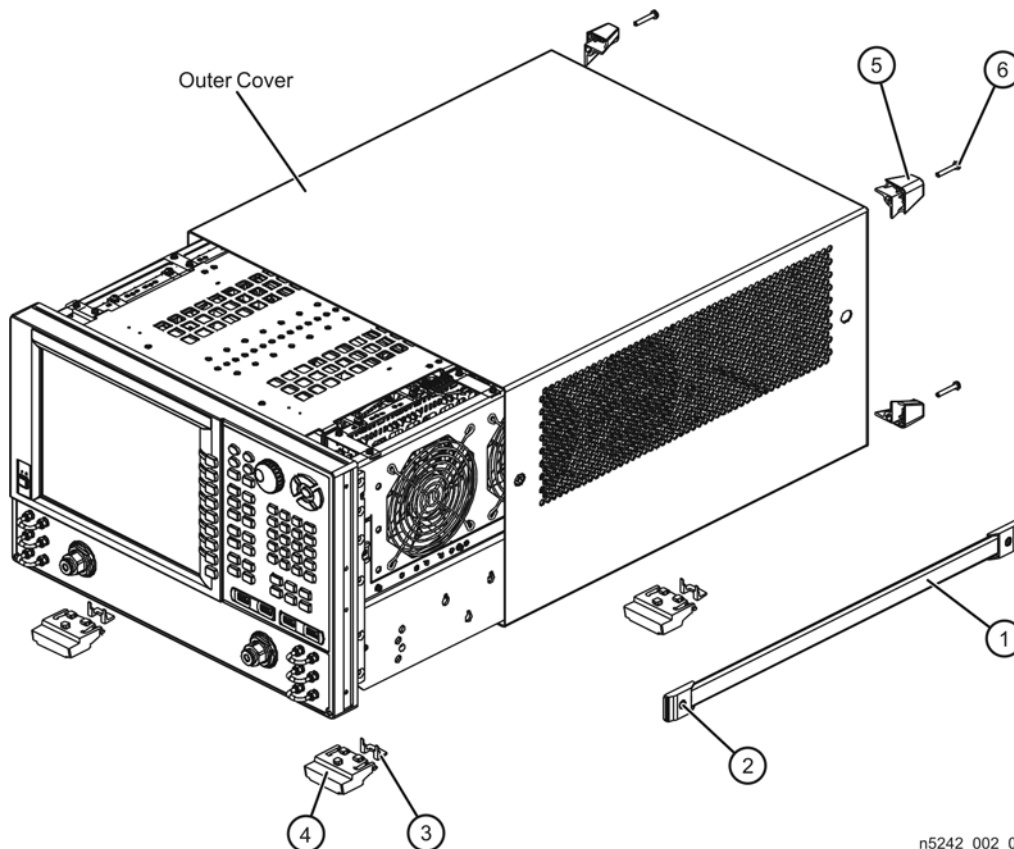

n5242_002_01

Step 9. Enable Option 219

Procedure Requirements

- The analyzer must be powered up and operating to perform this procedure.
- The Network Analyzer program must be running.

Option Enable Procedure

1. To start the option enable utility, press UTILITY **System**, then **Service**, then **Option Enable**. An option enable dialog box will appear.
2. Click the arrow in the **Select Desired Option** box. A list of available options will appear.
3. In the **Select Desired Option** list, click **219 - Src/Rcvr Atten & Bias Ts 2-Port**. Click **Enable**.
4. Click **Yes** in answer to the displayed question in the **Restart Analyzer?** box.
5. When the installation is complete, click **Exit**.

Option Verification Procedure

Once the analyzer has restarted and the Network Analyzer program is again running:

1. On the analyzer's **Help** menu, click **About Network Analyzer**.
2. Verify that "219" is listed after "Options:" in the display. Click **OK**.

NOTE If Option 219 has not been enabled, perform the "[Option Enable Procedure](#)" again. If the option is still not enabled, contact Agilent Technologies. Refer to "[Getting Assistance from Agilent](#)" on page 3.

Step 10. Perform Post-Upgrade Adjustments and Calibration

Adjustments

The following adjustments must be made due to the hardware changes of the analyzer.

- source adjustment
- receiver adjustment

These adjustments are described in the PNA Service Guide and in the PNA on-line HELP. A list of equipment required to perform these adjustments is also found in the service guide.

To view the Service Guide online, use the following steps:

1. Go to www.agilent.com.
2. In the Search box, enter the model number of your analyzer, N5242A, and click **Search**.
3. Click [Technical Support > Manuals](#).
4. Click [Service Manual](#).
5. Click the service guide title to load the PDF file.
6. When the PDF of the Service Guide is displayed, scroll through the Contents section bookmarks to locate the “Tests & Adjustments” chapter.

After the specified adjustments have been performed, the analyzer should operate and phase lock over its entire frequency range.

Operator’s Check

Perform the Operator’s Check to check the basic functionality of the analyzer. For instructions, refer to the “Tests & Adjustments” chapter of the Service Guide.

If you experience difficulty with the basic functioning of the analyzer, contact Agilent. Refer to [“Contacting Agilent” on page 3](#).

Calibration

Although the analyzer functions, its performance relative to its specifications has not been verified. It is recommended that a full instrument calibration be performed using the analyzer’s internal performance test software. Refer to the analyzer’s service guide for information on this performance test software.

